

Lab. 08

CHARACTERIZATION OF CURRENT MIRRORS

1. DC analysis of current mirror

- Carry out a DC analysis of the following circuits.
 - Basic current mirror
 - Cascode current mirror
 - Wide swing cascade current mirror
- Evaluate the output voltage range and the output resistance of the circuits for the output voltage from 0.0V to 5.0V. The power supply voltage is 5.0V and the reference current is 20uA.

Assuming that the drain and source length (L_D , L_S) are $3u$.

$$A_D = A_S = 3u * W$$

$$P_D = P_S = 2 * 3u + W$$

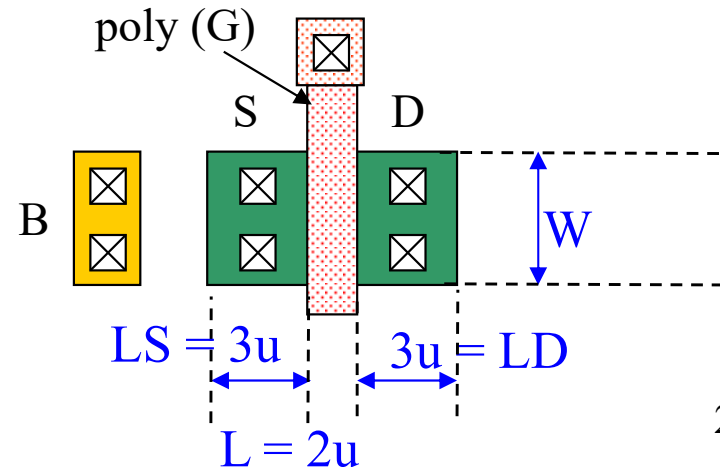

Schematic

The relative error tolerance (RELTOL) should be specified at small value, because the calculation of the small signal-resistance requires highly accurate current and voltage value.

```
.lib cmos.lib  
.dc V3 0V 5V 20mV  
.options reltol=1e-9
```

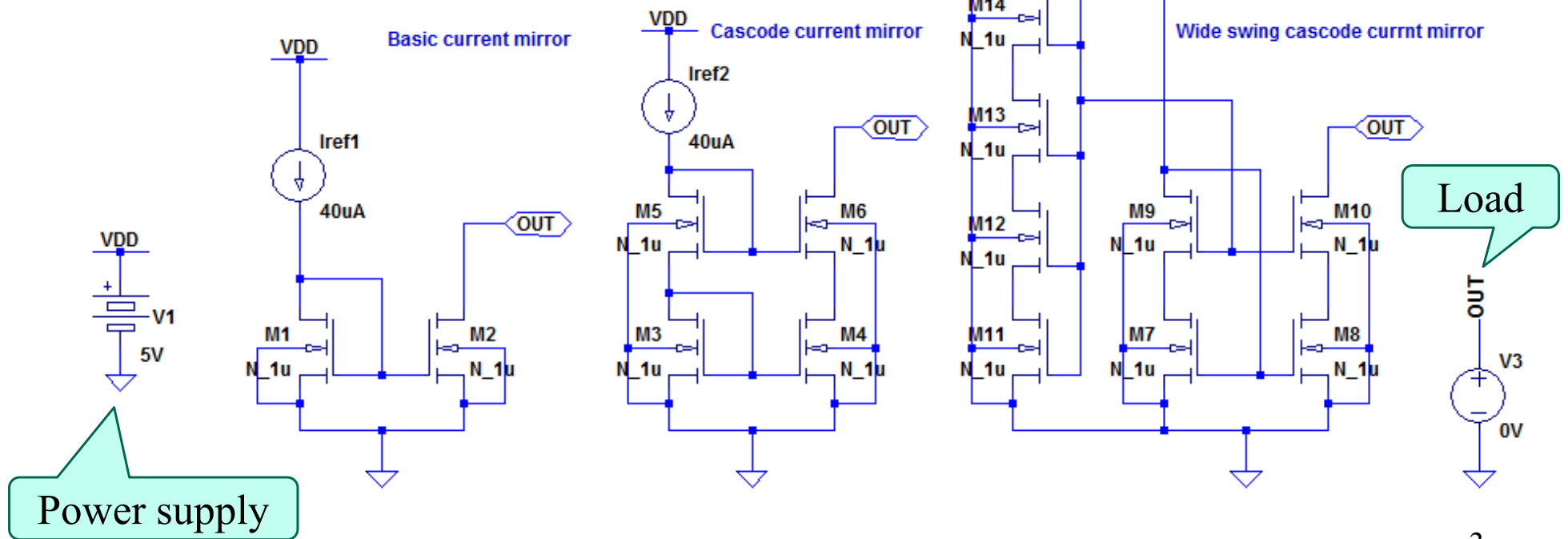

Parameters

MOSFET	L(m)	W(m)	M	AD, AS(m ²)	PD, PS(m)	W/L
M1~M10	2u	20u	2	60p	26u	20
M11~M15	2u	20u	2	60p	26u	2

$$\Delta_{OV1-10} = \sqrt{\frac{2I_{DS}}{\beta_n}} = \sqrt{\frac{2 \cdot 40u}{98u \cdot 20}} = 0.20V$$

If $\Delta_{OV} = 0.20V$,
 $W/L = 10, I_{DS} = 20uA$
 $W/L = 20, I_{DS} = 40uA$

$$\Delta_{OV11-15} = \sqrt{\frac{2I_{DS}}{\beta_n}} = \sqrt{\frac{2 \cdot 40u}{98u \cdot 4}} = 0.45V$$

See Lab.7. $K_p = 98uA/V^2$ for n-ch and $33uA/V^2$ for p-ch.

2. DC analysis of regulated drain current mirror

- Carry out a DC analysis of the regulated drain current mirror.
- Estimate the output swing if the required output current is in error by less than 1ppm of I_{ref} .

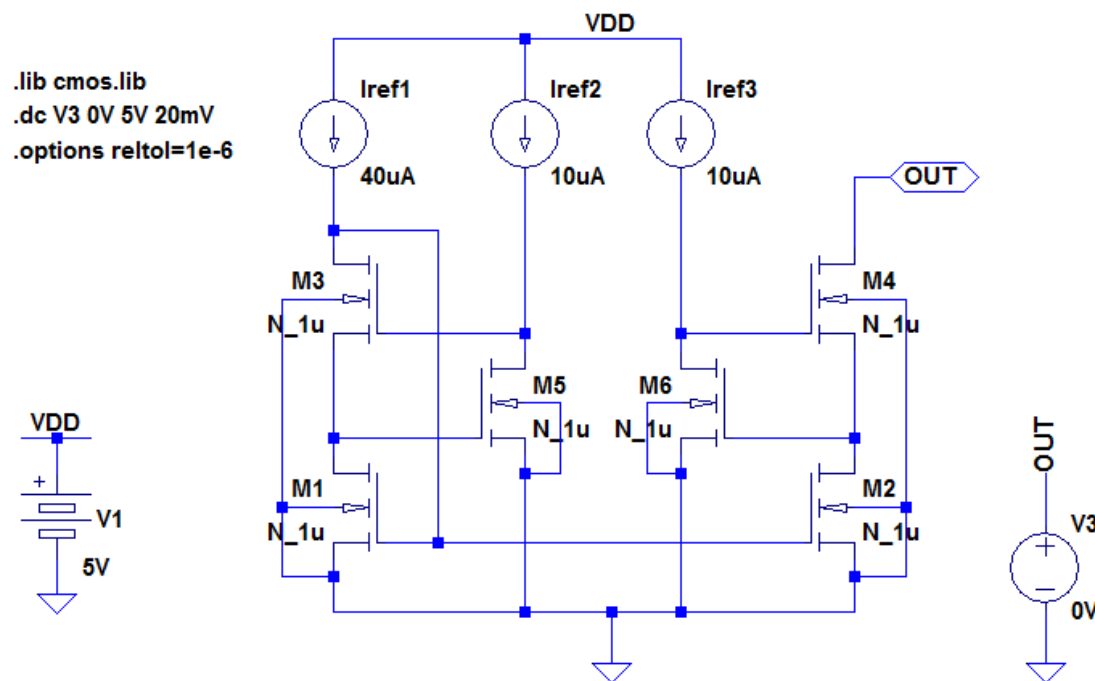

Parameters

MOSFET	L(m)	W(m)	M	AD, AS(m ²)	PD, PS(m)	W/L
M1~M4	2u	20u	2	60p	26u	20
M5~M6	2u	20u	8	60p	26u	80

Note:

You cannot calculate the output resistance of the regulated drain current mirror designed with the long channel MOSFETs. Because the calculation accuracy of LTspice is less than pA. and the output resistance of this circuits is typically 10G – 1000GΩ.

You may try to specify smaller relative error tolerance (RELTOL) and absolute current error tolerance (ABSTOL) with .options directive, but in compensation for it, you will encounter the convergence problem.